

RICAMBI E LAVORAZIONI SUPPLEMENTARI  
SPARE PARTS AND ADDITIONAL WORKING  
PIECES DE RECHANGE  
ERSATZTEILE  
ALKATRÉSZEK ÉS TARTOZÉKOK



7

**SPARE PARTS AND ADDITIONAL WORKING**

 <b>CS</b> p. 523	 <b>C010</b> p. 524	 <b>C011</b> p. 525	 <b>C013</b> p. 526	 <b>C003</b> p. 527	 <b>C004</b> p. 527
 <b>C005</b> p. 528	 <b>C016</b> p. 529	 <b>C017</b> p. 530	 <b>C019</b> p. 531	 <b>C020</b> p. 532	 <b>C022</b> p. 533
 <b>C024</b> p. 534	 <b>C025</b> p. 535	 <b>C028</b> p. 535	 <b>C030</b> p. 536	 <b>C032</b> p. 536	 <b>C035</b> p. 537
 <b>C040</b> p. 538	 <b>C040</b> p. 538	 <b>C040</b> p. 539	 <b>C042</b> p. 539	 <b>C044</b> p. 540	 <b>C046</b> p. 540
 <b>C047</b> p. 541	 <b>C048</b> p. 541	 <b>C207 - C208</b> p. 542	 <b>C207 - C208</b> p. 543	 <b>C205 - C206</b> p. 544	 <b>AA00</b> p. 545
 <b>ACH</b> p. 546	 <b>ACHET</b> p. 546	 <b>ACHTC</b> p. 546	 <b>ACHTT</b> p. 547	 <b>SUPP</b> p. 547	 <b>SUPP</b> p. 547
 <b>SUPP</b> p. 547	 <b>LAV</b> p. 547-548				

CS

## HWM Profile turnover knives



Coltelli sagomati in HW • Disponibili in diverse misure • Da applicare su teste e punte portacoltelli (art. TS e TPS)

HW profiled turnover knives • Available in different size • To mount on cutterheads TS and TPS

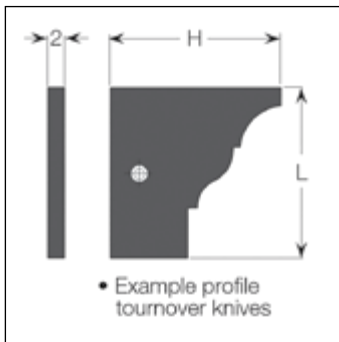

● = Ready in stock ■ = Delivery time 20 working days △ = On request

L	H	Code	€ per unit ord. 6 pcs	€ per unit ord. 12 pcs	€ per unit ord. 24 pcs	€ per unit ord. 48 pcs	€ per unit ord. 96 pcs
20	20	■ CS00M2020AAA					
20	25	■ CS00M2025AAA					
20	30	■ CS00M2030AAA					
20	35	■ CS00M2035AAA					
25	20	■ CS00M2520AAA					
25	25	■ CS00M2525AAA					
25	30	■ CS00M2530AAA					
25	35	■ CS00M2535AAA					
30	20	■ CS00M3020AAA					
30	25	■ CS00M3025AAA					
30	30	■ CS00M3030AAA					
30	35	■ CS00M3035AAA					
30	40	■ CS00M3040AAA					
35	20	■ CS00M3520AAA					
35	25	■ CS00M3525AAA					
35	30	■ CS00M3530AAA					
35	35	■ CS00M3535AAA					
35	40	■ CS00M3540AAA					
40	20	■ CS00M4020AAA					
40	25	■ CS00M4025AAA					
40	30	■ CS00M4030AAA					
40	35	■ CS00M4035AAA					
40	40	■ CS00M4040AAA					
40	45	■ CS00M4045AAA					
50	20	■ CS00M5020AAA					
50	25	■ CS00M5025AAA					
50	30	■ CS00M5030AAA					
50	35	■ CS00M5035AAA					
50	40	■ CS00M5040AAA					
50	45	■ CS00M5045AAA					
50	50	■ CS00M5050AAA					
60	20	■ CS00M6020AAA					
60	25	■ CS00M6025AAA					
60	30	■ CS00M6030AAA					
60	35	■ CS00M6035AAA					
60	40	■ CS00M6040AAA					
80	20	■ CS00M8020AAA					
80	25	■ CS00M8025AAA					
80	30	■ CS00M8030AAA					
80	35	■ CS00M8035AAA					
80	40	■ CS00M8040AAA					

Spec. CS00M99

TAGLIO / SEZIONATURA  
SAWINGDIAMANTE  
DIAMONDFRESATURA  
CUTTINGPANTOGRAFATURA  
ROUTINGFORATURA  
BORINGMANDRINI / ATTACCHI  
CHUCKS & CLAMPING SYSTEMRICAMBI E LAVORAZIONI SUPP.  
SPARE PARTS & ADD. WORKING

Coltelli in HW  
per piallatrici

HW Streifenhobelmesser

Couteaux de dégauchisseuse  
HW

Фуговальные ножи с  
напайкой HW

**C010**

**HW Planing knives**



Rettificati e spogliati con ottimo grado di finitura • Disponibili in diverse misure • Indicati per lavorazioni su legno, suoi derivati, laminati e simili • Da montare su teste pialla art. T204 e T204H

Ground and polished with excellent finishing • Available in different sizes • Suitable for working wood, laminates and such • Can be used planer on cutterheads art.T204 and T204H



● = Ready in stock ■ = Delivery time 20 working days △ = On request

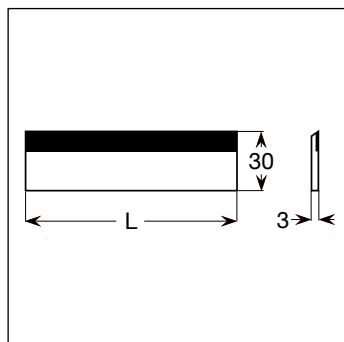

L	Code	€
60	■ C010M00600AA	
80	■ C010M0080AAA	
100	■ C010M0100AAA	
110	■ C010M0110AAA	
120	■ C010M0120AAA	
130	■ C010M0130AAA	
140	■ C010M0140AAA	
150	■ C010M0150AAA	
160	■ C010M0160AAA	
170	■ C010M0170AAA	
180	■ C010M0180AAA	
200	■ C010M0200AAA	
210	■ C010M0210AAA	
230	■ C010M0230AAA	
300	■ C010M0300AAA	
350	■ C010M0350AAA	
400	■ C010M0400AAA	
410	■ C010M0410AAA	
500	■ C010M0500AAA	
510	■ C010M0510AAA	
530	■ C010M0530AAA	
600	■ C010M0600AAA	
610	■ C010M0610AAA	
630	■ C010M0630AAA	
640	■ C010M0640AAA	
710	■ C010M0710AAA	
Spec.	C010M99	

TAGLIO / SEZIONATURA  
SAWING

DIAMANTE  
DIAMOND

FRESATURA  
CUTTING

PANTOGRAFATURA  
ROUTING

FORATURA  
BORING

MANDRINI / ATTACCHI  
CHUCKS & CLAMPING SYSTEM

RICAMBI E LAVORAZIONI SUPP.  
SPARE PARTS & ADD. WORKING

Coltelli in HS  
per piallatrici

HS Streifenhobelmesser

Couteaux de dégauchisseuse  
HS

Ножи фугальные HS

**C011**

**HS Planing knives**



Rettificati e spogliati con ottimo grado di finitura • Disponibili in diverse misure • Indicati per lavorazioni su legno naturale  
• Da montare su teste pialla art. T204 e T204H

Ground and polished with excellent finishing • Available in different sizes • Suitable for working wood • Can be used planer on cutterheads art.T204 and T204H

● = Ready in stock ■ = Delivery time 20 working days △ = On request

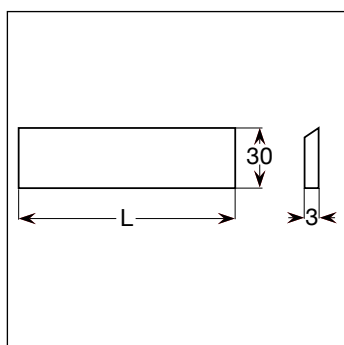

L	Code	€
60	● C011S0060AAA	
80	● C011S0080AAA	
100	● C011S0100AAA	
110	● C011S0110AAA	
120	● C011S0120AAA	
130	● C011S0130AAA	
140	● C011S0140AAA	
150	● C011S0150AAA	
160	● C011S0160AAA	
170	● C011S0170AAA	
180	● C011S0180AAA	
200	● C011S0200AAA	
210	● C011S0210AAA	
230	● C011S0230AAA	
300	● C011S0300AAA	
350	● C011S0350AAA	
400	● C011S0400AAA	
410	● C011S0410AAA	
500	● C011S0500AAA	
510	● C011S0510AAA	
530	● C011S0530AAA	
600	● C011S0600AAA	
610	● C011S0610AAA	
630	● C011S0630AAA	
640	● C011S0640AAA	
710	● C011S0710AAA	
800	● C011S0800AAA	
1000	● C011S1000AAA	
Spec.	C011S99	

TAGLIO / SEZIONATURA  
SAWING

DIAMANTE  
DIAMOND

FRESATURA  
CUTTING

PANTOGRAFATURA  
ROUTING

FORATURA  
BORING

MANDRINI / ATTACCHI  
CHUCKS & CLAMPING SYSTEM

RICAMBI E LAVORAZIONI SUPP.  
SPARE PARTS & ADD. WORKING

Coltelli in HS  
per piallatrici

HS Streifenhobelmesser

Couteaux de dégauchisseuse  
HS

Ножи фугальные HS

**C013**

**HS Planing knives**



Rettificati e spogliati con ottimo grado di finitura • Disponibili in diverse misure • Indicati per lavorazioni su legno naturale  
• Da montare su teste pialla a fissaggio meccanico art.T204 and T204H

Ground and polished with excellent finishing • Available in different sizes • Suitable for working wood • Can be used on planer cutterheads art.T204 and T204H

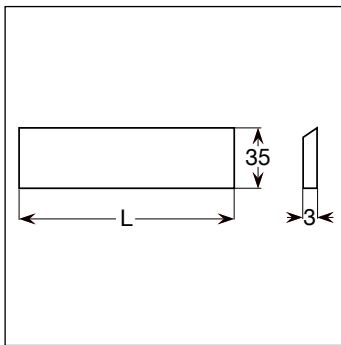

● = Ready in stock ■ = Delivery time 20 working days △ = On request

L	Code	€
60	● C013S0060AAA	
80	● C013S0080AAA	
100	● C013S0100AAA	
110	● C013S0110AAA	
120	● C013S0120AAA	
130	● C013S0130AAA	
140	● C013S0140AAA	
150	● C013S0150AAA	
160	● C013S0160AAA	
170	● C013S0170AAA	
180	● C013S0180AAA	
200	● C013S0200AAA	
210	● C013S0210AAA	
230	● C013S0230AAA	
300	● C013S0300AAA	
350	● C013S0350AAA	
400	● C013S0400AAA	
410	● C013S0400AAA	
500	● C013S0500AAA	
510	● C013S0510AAA	
530	● C013S0530AAA	
600	● C013S0600AAA	
610	● C013S0610AAA	
630	● C013S0630AAA	
640	● C013S0640AAA	
710	● C013S0710AAA	
800	● C013S0800AAA	
1000	● C013S1000AAA	
Spec.	C013S99	

TAGLIO / SEZIONATURA  
SAWING

DIAMANTE  
DIAMOND

FRESATURA  
CUTTING

PANTOGRAFATURA  
ROUTING

FORATURA  
BORING

MANDRINI / ATTACCHI  
CHUCKS & CLAMPING SYSTEM

RICAMBI E LAVORAZIONI SUPP.  
SPARE PARTS & ADD. WORKING

Coltelli  
autoposizionanti  
Centrolock

HS Wendehobelmesser  
Centrolock (Weinig)

Couteaux Centrolock

Ножи строгальные  
Centrolock

**C003**

**HS** Planing self positioning knives - Centrolock



Rettificati e spogliati con ottimo grado di finitura • Disponibili in diverse misure • Indicati per lavorazioni su legno naturale  
• Da montare su teste pialla a fissaggio meccanico art.T207 and T207H

Ground and polished with excellent finishing • Available in different sizes • Suitable for working wood • Can be used on planer cutterheads art.T207 and T207H

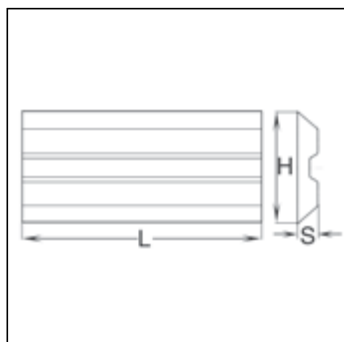

**HW**

● = Ready in stock ■ = Delivery time 20 working days △ = On request

L	H	S	Code	€
100	16	3	● C003S100AAAA	
130	16	3	● C003S130AAAA	
150	16	3	● C003S150AAAA	
180	16	3	● C003S180AAAA	
210	16	3	● C003S210AAAA	
230	16	3	● C003S230AAAA	
240	16	3	● C003S240AAAA	
650	16	3	■ C003S650AAAA	
Spec.			C003S99	

Coltelli  
autoposizionanti  
Centrolock

HW Wendehobelmesser  
Centrolock (Weinig)

Couteaux Centrolock

Ножи строгальные  
Centrolock

**C004**

**HW** Planing self positioning knives - Centrolock

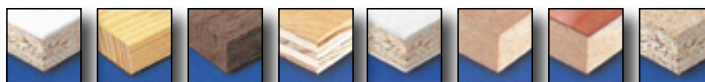

Rettificati e spogliati con ottimo grado di finitura • Disponibili in diverse misure • Indicati per lavorazioni su legno naturale  
• Da montare su teste pialla a fissaggio meccanico art.T207 and T207H

Ground and polished with excellent finishing • Available in different sizes • Suitable for working wood • Can be used on planer cutterheads art.T207 and T207H

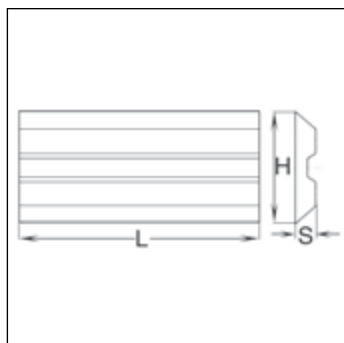

● = Ready in stock ■ = Delivery time 20 working days △ = On request

L	H	S	Code	€
100	16	3	■ C004M100AAAA	
130	16	3	■ C004M130AAAA	
150	16	3	■ C004M150AAAA	
180	16	3	■ C004M180AAAA	
210	16	3	■ C004M210AAAA	
230	16	3	■ C004M230AAAA	
240	16	3	■ C004M240AAAA	
Spec.			C004M99	

# C005

# HS Planing self positioning knives - Tersa



Rettificati e spogliati con ottimo grado di finitura • Disponibili in diverse misure • Indicati per lavorazioni su legno naturale  
• Da montare su teste pialla a fissaggio meccanico

Ground and polished with excellent finishing • Available in different sizes • Suitable for working wood • Can be used on planer cutterheads

● = Ready in stock ■ = Delivery time 20 working days △ = On request

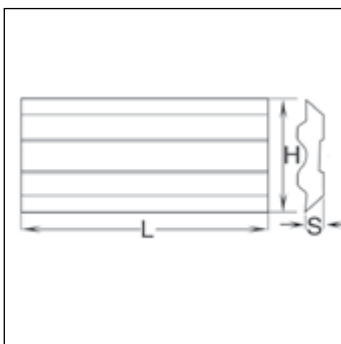

L	H	S	Code	€
80	10	2,3	■ C005S080AAAA	
100	10	2,3	■ C005S100AAAA	
110	10	2,3	■ C005S110AAAA	
120	10	2,3	■ C005S120AAAA	
130	10	2,3	■ C005S130AAAA	
150	10	2,3	■ C005S150AAAA	
170	10	2,3	■ C005S170AAAA	
180	10	2,3	■ C005S180AAAA	
210	10	2,3	■ C005S210AAAA	
230	10	2,3	■ C005S230AAAA	
250	10	2,3	■ C005S250AAAA	
260	10	2,3	■ C005S260AAAA	
300	10	2,3	■ C005S300AAAA	
310	10	2,3	■ C005S310AAAA	
350	10	2,3	■ C005S350AAAA	
400	10	2,3	■ C005S400AAAA	
410	10	2,3	■ C005S410AAAA	
420	10	2,3	■ C005S420AAAA	
430	10	2,3	■ C005S430AAAA	
450	10	2,3	■ C005S450AAAA	
500	10	2,3	■ C005S500AAAA	
510	10	2,3	■ C005S510AAAA	
520	10	2,3	■ C005S520AAAA	
530	10	2,3	■ C005S530AAAA	
540	10	2,3	■ C005S540AAAA	
610	10	2,3	■ C005S610AAAA	
630	10	2,3	■ C005S630AAAA	
635	10	2,3	■ C005S635AAAA	
640	10	2,3	■ C005S640AAAA	
650	10	2,3	■ C005S650AAAA	
710	10	2,3	■ C005S710AAAA	

Spec.

C005S99



# C016

## HWM Reversible knives



Rettificati e spogliati con ottimo grado di finitura • Disponibili in diverse misure • Indicati per lavorazioni su truciolari, laminati e simili • Da montare su utensili a fissaggio meccanico

Ground and polished with excellent finishing • Available in different sizes • Suitable for working chipboard, laminated and such • Can be used on cutterheads

● = Ready in stock ■ = Delivery time 20 working days △ = On request

L	H	S	X	Mod.	Code	€
7,5	9	1,5		A	● C016M07509AA	
9,6	9	1,5		A	● C016M09609AA	
12*	9	1,5		A	● C016M12009AA	
14,6	9	1,5		A	● C016M14609AA	
20	9	1,5		A	● C016M20009AA	
30	9	1,5	14	B	● C016M30009BA	
40	9	1,5	26	B	● C016M40009BA	
49,5**	9	1,5	26	B	● C016M49509AA	
50	9	1,5	26	B	● C016M50009BA	
60	9	1,5	26	B	● C016M60009BA	

Spec.					C016M99	
-------	--	--	--	--	---------	--

- \* Coltelli L=12 mm spogliati su 4 lati
- \* Knives L=12 mm with 4 cleared side angles
- \*\* Coltelli L=49,5 mm spogliati su 3 lati
- \*\* Knives L=49,5 mm with 3 cleared side angles

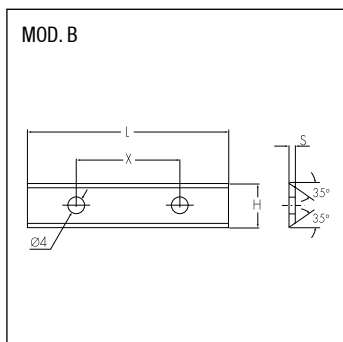
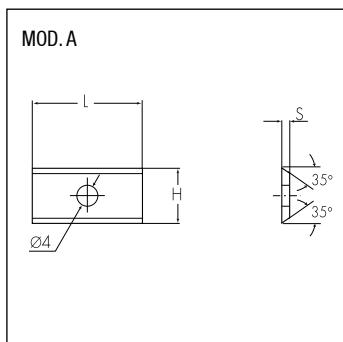

TAGLIO / SEZIONATURA  
SAWING

DIAMANTE  
DIAMOND

FRESATURA  
CUTTING

PANTOGRAFATURA  
ROUTING

FORATURA  
BORING

MANDRINI / ATTACCHI  
CHUCKS & CLAMPING SYSTEM

RICAMBI E LAVORAZIONI SUPP.  
SPARE PARTS & ADD. WORKING

Coltelli reversibili  
in HWM

HWM Wendeplatten

HWM Couteaux réversibles

Сменные ножи HWM

**C017**

**HWM Reversible knives**

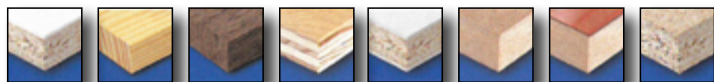

Rettificati e spogliati con ottimo grado di finitura • Disponibili in diverse misure • Indicati per lavorazioni su legno naturali teneri • Da montare su utensili a fissaggio meccanico

Ground and polished with excellent finishing • Available in different sizes • Suitable for working soft wood • Can be used on cutterheads

TAGLIO / SEZIONATURA  
SAWING



DIAMANTE  
DIAMOND

FRESATURA  
CUTTING

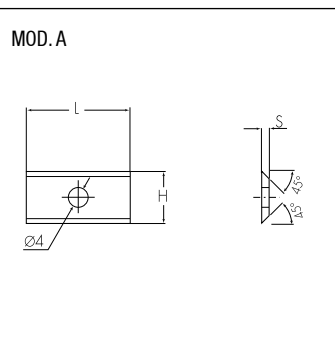

PANTOGRAFATURA  
ROUTING

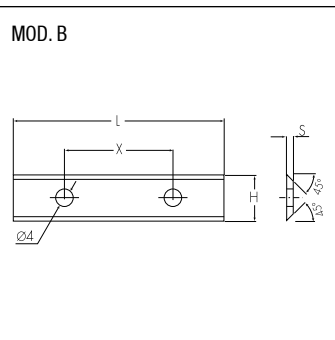

FORATURA  
BORING

MANDRINI / ATTACCHI  
CHUCKS & CLAMPING SYSTEM

RICAMBI E LAVORAZIONI SUPP.  
SPARE PARTS & ADD. WORKING

● = Ready in stock ■ = Delivery time 20 working days △ = On request

L	H	S	X	Mod.	Code	€
7,5	12	1,5		A	● C017M07512AA	
9,6	12	1,5		A	● C017M09612AA	
12	12	1,5		A	● C017M12012AA	
15	12	1,5		A	● C017M15012AA	
20	12	1,5		A	● C017M20012AA	
30	12	1,5	14	B	● C017M30012BA	
40	12	1,5	26	B	● C017M40012BA	
50	12	1,5	26	B	● C017M50012BA	
60	12	1,5	26	B	● C017M60012BA	

Spec.

C017M99

\* Coltelli L=12 mm spogliati su 4 lati  
\* Knives L=12 mm with 4 cleared side angles

# C019

## HWM Reversible knives



Rettificati e spogliati con ottimo grado di finitura • Disponibili in diverse misure • Indicati per lavorazioni su legni naturali  
• Da montare su utensili a fissaggio meccanico

Ground and polished with excellent finishing • Available in different sizes • Suitable for working wood • Can be used on cutterheads

● = Ready in stock ■ = Delivery time 20 working days △ = On request

L	H	S	X	Mod.	Code	€
12	12	1,5		A	● C019M12012AA	
20	12	1,5		A	● C019M20012AA	
30	12	1,5	14	B	● C019M30012BA	
40	12	1,5	26	B	● C019M40012BA	
50	12	1,5	26	B	● C019M50012BA	
60	12	1,5	26	B	● C019M60012BA	
Spec.					C019M99	

\* Coltelli L=12 mm spogliati su 4 lati  
\* Knives L=12 mm with 4 cleared side angles

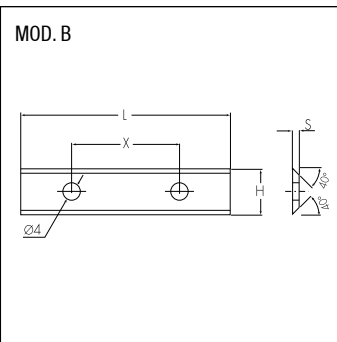
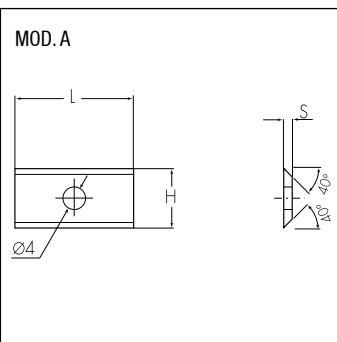

TAGLIO / SEZIONATURA  
SAWING

DIAMANTE  
DIAMOND

FRESATURA  
CUTTING

PANTOGRAFATURA  
ROUTING

FORATURA  
BORING

MANDRINI / ATTACCHI  
CHUCKS & CLAMPING SYSTEM

RICAMBI E LAVORAZIONI SUPP.  
SPARE PARTS & ADD. WORKING

# C020

## HWM Reversible knives



Rettificati e spogliati con ottimo grado di finitura • Disponibili in diverse misure • Indicati per lavorazioni su truciolari, laminati e simili

Ground and polished with excellent finishing • Available in different sizes • Suitable for working chipboard, laminated and such • Can be used on cutterheads

TAGLIO / SEZIONATURA  
SAWING



DIAMANTE  
DIAMOND

FRESATURA  
CUTTING

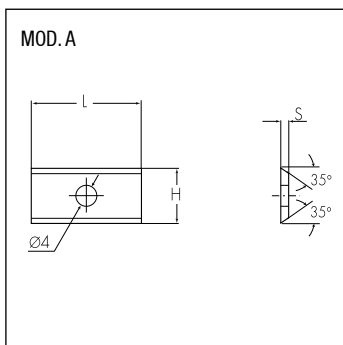

PANTOGRAFATURA  
ROUTING

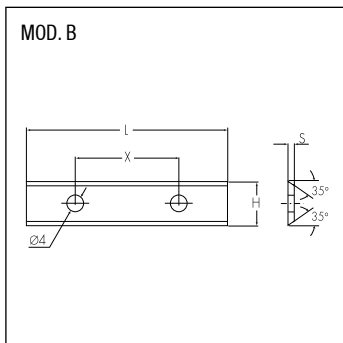

FORATURA  
BORING

MANDRINI / ATTACCHI  
CHUCKS & CLAMPING SYSTEM

RICAMBI E LAVORAZIONI SUPP.  
SPARE PARTS & ADD. WORKING

● = Ready in stock   ■ = Delivery time 20 working days   △ = On request

L	H	S	X	Mod.	Code	€
7,5	12	1,5		A	● C020M07512AA	
9,6	12	1,5		A	● C020M09612AA	
12	12	1,5		A	● C020M12012AA	
15	12	1,5		A	● C020M15012AA	
20	12	1,5		A	● C020M20012AA	
25	12	1,5			● C020M25012AA	
30	12	1,5	14	B	● C020M30012AB	
40	12	1,5	26	B	● C020M40012AB	
50	12	1,5	26	B	● C020M50012AB	
60	12	1,5	26	B	● C020M60012AB	
80	13	2,2	60	B	● C020M80013AB	
100	13	2,2	60	B	■ C020M100013B	
120	13	2,2	60	B	■ C020M120013B	

Spec.

C020M99

\* Coltelli L=12 mm spogliati su 4 lati  
\* Knives L=12 mm with 4 cleared side angles

# C022

## HWM Reversible knives



Rettificati e spogliati con ottimo grado di finitura • Disponibili in diverse misure • Buona tenuta di taglio • Indicati per lavorazioni su truciolari, laminati e simili

Ground and polished with excellent finishing • Available in different sizes • Good tool life • Suitable for working chipboard, laminated and such • Can be used on cutterheads

● = Ready in stock ■ = Delivery time 20 working days △ = On request

L	H	S	X	Mod.	Code	€
7,5	12	1,5		A	● C022M07512AA	
12	12	1,5		A	● C022M01212AA	
15	12	1,5		A	● C022M01512AA	
20	12	1,5		A	● C022M02012AA	
30	12	1,5	14	B	● C022M03012BA	
50	12	1,5	26	B	● C022M05012BA	
60	12	1,5	26	B	● C022M06012BA	
Spec.					C022M99	

\* Coltelli L=12 mm spogliati su 4 lati  
\* Knives L=12 mm with 4 cleared side angles

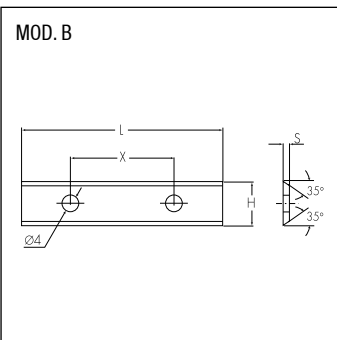
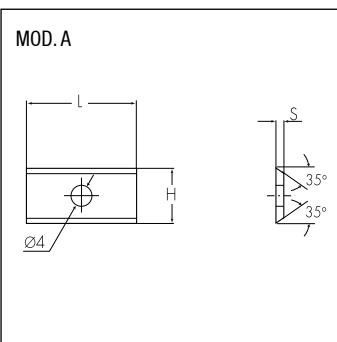

TAGLIO / SEZIONATURA  
SAWING

DIAMANTE  
DIAMOND

FRESATURA  
CUTTING

PANTOGRAFATURA  
ROUTING

FORATURA  
BORING

MANDRINI / ATTACCHI  
CHUCKS & CLAMPING SYSTEM

RICAMBI E LAVORAZIONI SUPP.  
SPARE PARTS & ADD. WORKING

Coltelli reversibili in HWM ad alto rendimento

HWM Wendeplatten

HWM Couteaux réversibles

Сменные ножи HWM

**C024**

**HWM Reversible knives - High efficiency**



Rettificati e spogliati con ottimo grado di finitura • Disponibili in diverse misure • Elevata tenuta di taglio • Indicati per lavorazioni su truciolari, laminati e simili

Ground and polished with excellent finishing • Available in different sizes • Excellent tool life • Suitable for working chipboard, laminated and such • Can be used on cutterheads

TAGLIO / SEZIONATURA  
SAWING

DIAMANTE  
DIAMOND

FRESATURA  
CUTTING

PANTOGRAFATURA  
ROUTING

FORATURA  
BORING

MANDRINI / ATTACCHI  
CHUCKS & CLAMPING SYSTEM

RICAMBI E LAVORAZIONI SUPP.  
SPARE PARTS & ADD. WORKING



MOD. A

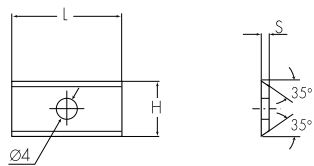

MOD. B

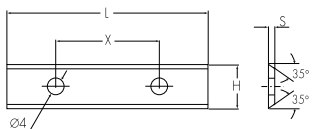

● = Ready in stock ■ = Delivery time 20 working days △ = On request

L	H	S	X	Mod.	Code	€
20	12	1,5		A	● C024M02012AA	
30	12	1,5	14	B	● C024M03012BA	
50	12	1,5	26	B	● C024M05012BA	
Spec.					C024M99	

\* Coltelli L=12 mm spogliati su 4 lati  
\* Knives L=12 mm with 4 cleared side angles

Coltelli reversibili in HWM spogliati di testa

HWM Wendeplatten

HWM Couteaux réversibles

Сменные ножи HWM



## C025 HWM Reversible knives - Sides cleared



Rettificati e spogliati con ottimo grado di finitura • Spogliati frontalmente con possibilità di taglio sui 4 lati • Disponibili in diverse misure • Indicati in lavorazioni con esigenza di taglio frontale su truciolari, laminati e simili

Ground and polished with excellent finishing • Bottom clearance angle, all 4 sides can cut • Available in different sizes • Good tool life • Indicated for frontal cutting chipboard, laminated and such

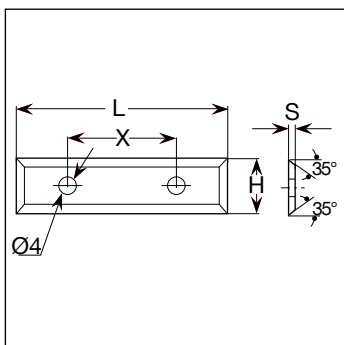

● = Ready in stock ■ = Delivery time 20 working days △ = On request

L	H	S	X	Code	€
29,5	12	1,5	14	● C025M29512AB	
49,5	12	1,5	26	● C025M49512AB	
Spec.				C025M99	

TAGLIO / SEZIONATURA  
SAWING

DIAMANTE  
DIAMOND

FRESATURA  
CUTTING

Coltelli reversibili in HWM

HWM Wendeplatten

HWM Couteaux réversibles

Сменные ножи HWM

## C028 HWM Reversible knives

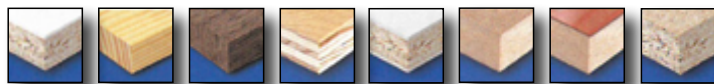

Rettificati e spogliati con ottimo grado di finitura • Disponibili in diverse misure • Indicati per lavorazioni su legni naturali • Da montare su utensili a fissaggio meccanico

Ground and polished with excellent finishing • Available in different sizes • Suitable for working wood • Can be used on cutterheads

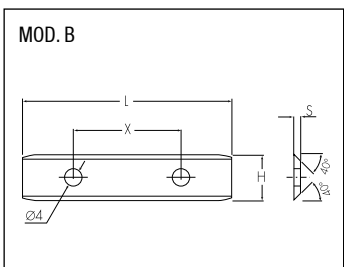
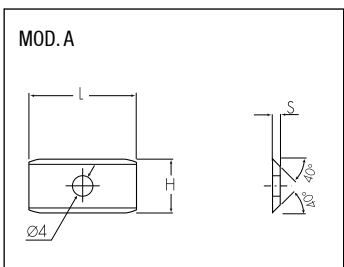

● = Ready in stock ■ = Delivery time 20 working days △ = On request

L	H	S	X	Mod.	Code	€
24	12	1,5		A	● C028M02412AA	
50	12	1,5	26	B	● C028M05012AB	
Spec.					C028M99	

PANTOGRAFATURA  
ROUTING

FORATURA  
BORING

MANDRINI / ATTACCHI  
CHUCKS & CLAMPING SYSTEM

RICAMBI E LAVORAZIONI SUPP.  
SPARE PARTS & ADD. WORKING



Mini coltelli reversibili  
in HWM

HWM Miniwendeplatten

HWM Mini couteaux  
réversibles

Сменные ножи HWM

TAGLIO / SEZIONATURA  
SAWING

DIAMANTE  
DIAMOND

FRESATURA  
CUTTING

PANTOGRAFATURA  
ROUTING

FORATURA  
BORING

MANDRINI / ATTACCHI  
CHUCKS & CLAMPING SYSTEM

RICAMBI E LAVORAZIONI SUPP.  
SPARE PARTS & ADD. WORKING

## C030

## HWM Reversible knives



Rettificati e spogliati con ottimo grado di finitura • Disponibili in diverse misure • Da montare su punte pantografo a fissaggio meccanico.

Ground and polished with excellent finishing • Available in different sizes • Suitable for working wood • Can be used on router bit cutterheads



● = Ready in stock ■ = Delivery time 20 working days △ = On request

L	H	S	Code	€
12	5,5	1,1	■ C030M01255AA	
20	5,5	1,1	■ C030M02055AA	
30	5,5	1,1	■ C030M03055AA	
40	5,5	1,1	■ C030M04055AA	
50	5,5	1,1	■ C030M05055AA	
Spec.			C030M99	

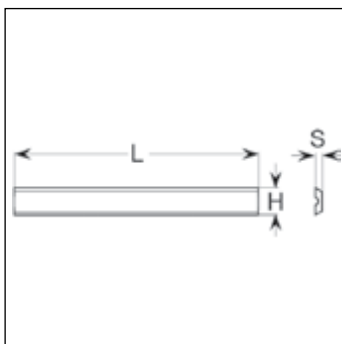

Mini coltelli reversibili  
in HWM

HWM Miniwendeplatten

HWM Mini couteaux  
réversibles

Сменные ножи HWM

## C032

## HWM Reversible knives



Rettificati e spogliati con ottimo grado di finitura • Disponibili in diverse misure • Da montare su punte pantografo a fissaggio meccanico

Ground and polished with excellent finishing • Available in different sizes • Suitable for working wood • Can be used on router bit cutterheads



● = Ready in stock ■ = Delivery time 20 working days △ = On request

L	H	S	Code	€
12	5,5	1,1	■ C032M01255AA	
20	5,5	1,1	■ C032M02055AA	
30	5,5	1,1	■ C032M03055AA	
40	5,5	1,1	■ C032M04055AA	
50	5,5	1,1	■ C032M05055AA	
82	5,5	1,1	■ C032M08255AA	
Spec.			C032M99	

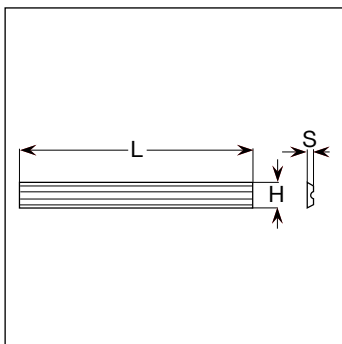





**C035** **HWM Reversible knives**



Rettificati e spogliati con ottimo grado di finitura • Spogliati frontalmente con possibilità di taglio sui 4 lati • Disponibili in diverse misure • Da montare su punte pantografo a fissaggio meccanico

Ground and polished with excellent finishing • Bottom clearance angle, all 4 sides can cut • Available in different sizes • To mount on router bits cutterheads

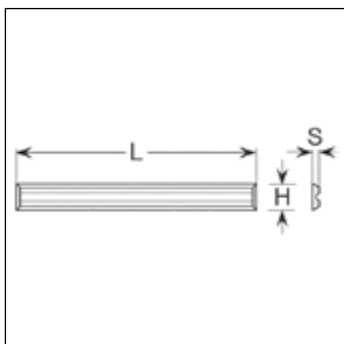

● = Ready in stock ■ = Delivery time 20 working days △ = On request

L	H	S	Code	€
29,5	5,5	1,1	■ C035M2955AA	
49,5	5,5	1,1	■ C035M4955AA	
Spec.			C035M99	

TAGLIO / SEZIONATURA  
SAWING

DIAMANTE  
DIAMOND

FRESATURA  
CUTTING

PANTOGRAFATURA  
ROUTING

FORATURA  
BORING

MANDRINI / ATTACCHI  
CHUCKS & CLAMPING SYSTEM

RICAMBI E LAVORAZIONI SUPP.  
SPARE PARTS & ADD. WORKING

Rasanti reversibili  
in HWM

HWM Vorschneider

HWM Araseurs réversibles

Сменные ножи HWM

## C040

## HWM Reversible spurs

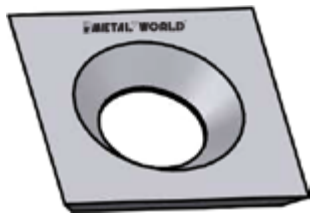
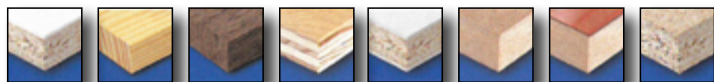

Rettificati e spogliati con ottimo grado di finitura • Spogliati sui 4 lati • Disponibili in diverse misure • Da montare su utensili a fissaggio meccanico

Ground and polished with excellent finishing • 4 sides clearance angle • Available in different sizes • To mount on cutterheads

● = Ready in stock ■ = Delivery time 20 working days △ = On request

L	H	S	Code	€
14	14	1,2	● C040M14012AA	
14	14	2	● C040M14020AA	
Spec.			C040M99	

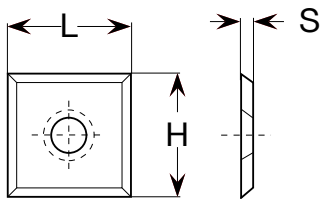

TAGLIO / SEZIONATURA  
SAWING

DIAMANTE  
DIAMOND

FRESATURA  
CUTTING

PANTOGRAFATURA  
ROUTING

Coltelli reversibili  
in HWM

HWM Wendemesser

HWM Couteaux réversibles

Сменные ножи HWM

## C040

## HWM Reversible knives



Rettificati e spogliati con ottimo grado di finitura • Spogliati sui 4 lati • Disponibili in diverse misure • Da montare su utensili a fissaggio meccanico

Ground and polished with excellent finishing • 4 sides clearance angle • Available in different sizes • To mount on cutterheads

● = Ready in stock ■ = Delivery time 20 working days △ = On request

L	H	S	R	Code	€
15	15	2,5	150	● C040M15025AA	
Spec.				C040M99	

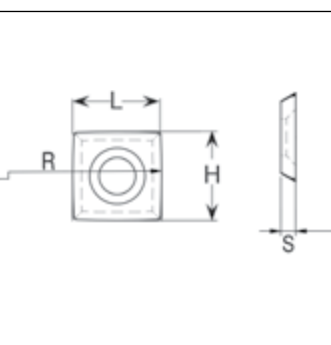

FORATURA  
BORING

MANDRINI / ATTACCHI  
CHUCKS & CLAMPING SYSTEM

RICAMBI E LAVORAZIONI SUPP.  
SPARE PARTS & ADD. WORKING

Rasanti reversibili  
in HWM

HWM Vorschneider

HWM Araseurs réversibles

Сменные ножи HWM

## C040

## HWM Reversible knives

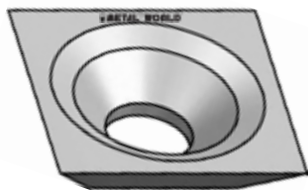
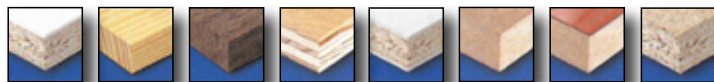

Rettificati e spogliati con ottimo grado di finitura • Spogliati sui 4 lati • Disponibili in diverse misure • Da montare su utensili a fissaggio meccanico

Ground and polished with excellent finishin • 4 sides clearance angle • Available in different sizes • To mount on cutterheads

● = Ready in stock ■ = Delivery time 20 working days △ = On request

L	H	S	Code	€
21	21	5,5	● C040M21055AA	
Spec.			C040M99	

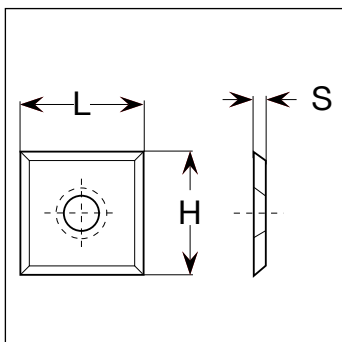

TAGLIO / SEZIONATURA  
SAWING

DIAMANTE  
DIAMOND

FRESATURA  
CUTTING

PANTOGRAFATURA  
ROUTING

Rasanti triangolari  
in HWM

HWM Dreikant Vorschneider

HWM Araseurs trianglers

Сменные треугольные  
ножи HWM

## C042

## HWM Triangular spurs

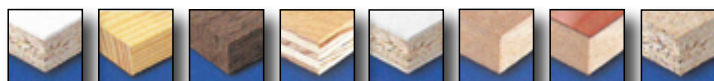

Rettificati e spogliati con ottimo grado di finitura • Disponibili in diverse misure • Da montare su utensili a fissaggio meccanico

Ground and polished with excellent finishing • Available in different sizes • To mount on cutterheads

● = Ready in stock ■ = Delivery time 20 working days △ = On request

L	H	S	Code	€
22	19	2	● C042M220190A	
Spec.			C042M99	

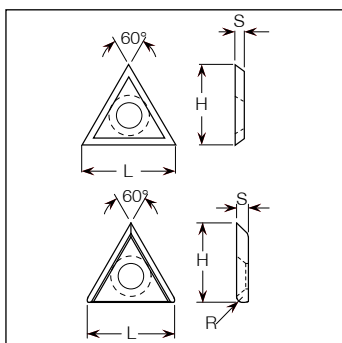

L	H	S	R	Code	€
21,9	19	2,5	1,5	● C042M219250A	
Spec.				C042M99	

FORATURA  
BORING

MANDRINI / ATTACCHI  
CHUCKS & CLAMPING SYSTEM

RICAMBI E LAVORAZIONI SUPP.  
SPARE PARTS & ADD. WORKING



**Inserti reversibili in HWM per smussare e raggiare**

**HWM Fase und Abrundmesser**

**HWM Plaquettes réversibles pour chanfreiner et arrondir**

**Сменные ножи HWM**

TAGLIO / SEZIONATURA  
SAWING

DIAMANTE  
DIAMOND

FRESATURA  
CUTTING

PANTOGRAFATURA  
ROUTING

FORATURA  
BORING

MANDRINI / ATTACCHI  
CHUCKS & CLAMPING SYSTEM

RICAMBI E LAVORAZIONI SUPP.  
SPARE PARTS & ADD. WORKING

## C044

## HWM Beveling and rounding inserts



Rettificati e spogliati con ottimo grado di finitura • Disponibili in diverse misure • Da montare su utensili a fissaggio meccanico

Ground and polished with excellent finishing • Available in different sizes • To mount on cutterheads

● = Ready in stock ■ = Delivery time 20 working days △ = On request

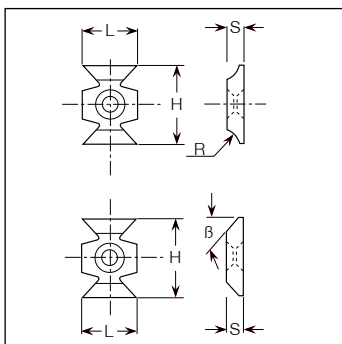

L	H	S	R	Code	€
16	22	5	1,5	● C044M220R15A	
16	22	5	2	● C044M220R20A	
16	22	5	3	● C044M220R30A	
Spec.					C044M99

L	H	S	B	Code	€
16	22	5	45°	● C044M220AASA	
Spec.					C044M99

**Inserti per incastri in HWM**

**HWM Nutmesser**

**HWM Plaquettes à rainier**

**Сменные режущие пластины HWM**

## C046

## HWM Reversible grooving inserts

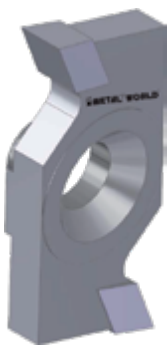

Rettificati e spogliati con ottimo grado di finitura • Disponibili in diverse misure • Da montare su utensili a fissaggio meccanico

Ground and polished with excellent finishing • Available in different sizes • To mount on cutterheads

● = Ready in stock ■ = Delivery time 20 working days △ = On request

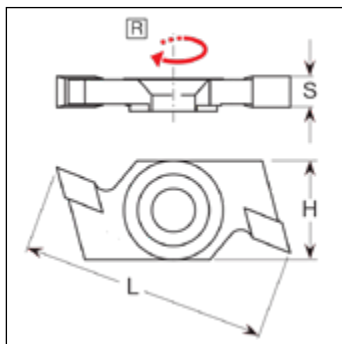

S	H	L	Left Code	Right Code	€
3	16	40	● C046M03AAAAL	● C046M03AAAAR	
4	16	40	● C046M04AAAAL	● C046M04AAAAR	
5	16	40	● C046M05AAAAL	● C046M05AAAAR	
6	16	40	● C046M06AAAAL	● C046M06AAAAR	
Spec.			C046M99L	C046M99R	

Inserti per incastri in HWM

HWM Nutmesser

HWM Plaquettes à rainer

Сменные режущие пластины HWM



**C047** **HWM Grooving inserts**

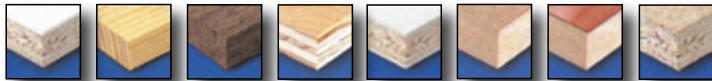

Rettificati e spogliati con ottimo grado di finitura • Disponibili in diverse misure • Da montare su utensili a fissaggio meccanico

Ground and polished with excellent finishing • Available in different sizes • To mount on cutterheads

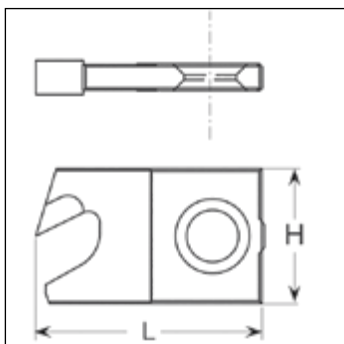

● = Ready in stock ■ = Delivery time 20 working days △ = On request

S	H	L	Code	€
3	20	25,6	● C047M250030A	
4	20	25,6	● C047M250040A	
5	20	25,6	● C047M250050A	
6	20	25,6	● C047M250060A	
Spec.			C047M99	

TAGLIO / SEZIONATURA SAWING

DIAMANTE DIAMOND

FRESATURA CUTTING

Inserti per incastri in HWM

HWM Nutmesser

HWM Plaquettes à rainer

Сменные режущие пластины HWM

**C048** **HWM Grooving inserts**

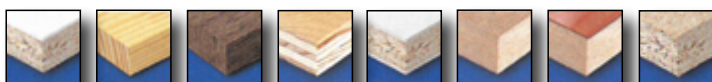

Rettificati e spogliati con ottimo grado di finitura • Disponibili in diverse misure • Da montare su utensili a fissaggio meccanico

Ground and polished with excellent finishing • Available in different sizes • To mount on cutterheads

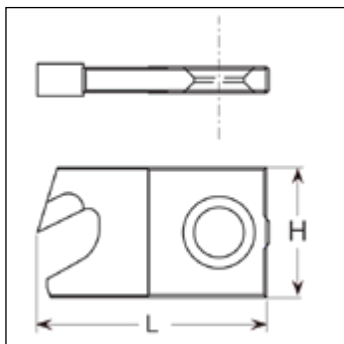

● = Ready in stock ■ = Delivery time 20 working days △ = On request

S	H	L	Code	€
3	20	35,6	● C048M350030A	
4	20	35,6	● C048M350040A	
5	20	35,6	● C048M350050A	
6	20	35,6	● C048M350060A	
Spec.			C048M99	

PANTOGRAFATURA ROUTING

FORATURA BORING

MANDRINI / ATTACCHI CHUCKS & CLAMPING SYSTEM

RICAMBI E LAVORAZIONI SUPP. SPARE PARTS & ADD. WORKING



Coltelli HW profilabili  
per teste T206-T206H-T206W



HW Blanketts  
Rückenverzahnt  
für T206-T206H-T206W



Plaquettes HW de rechange  
por porte-outils  
T206-T206H-T206W



Ножи HW под  
профилирования для  
головок T206-T206H-T206W

## C207-C208

## HW Profilable knives for T206-T206H-T206W cutterheads

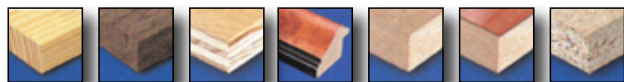

Coltelli in HW zigrinati (spessore mm 8) • Disponibili in diverse misure • Fornibili grezzi o profilati • Indicati per la lavorazione di legni massicci • Da montare su teste portacoltelli T206-T206H-T206W

HW knurled knives (thickness 8 mm) • Available in different sizes • Supplied profiled or not profiled • Suitable for working solid wood • To mount on cutterheads T206-T206H-T206W

TAGLIO / SEZIONATURA  
SAWING

DIAMANTE  
DIAMOND

FRESATURA  
CUTTING

PANTOGRAFATURA  
ROUTING

FORATURA  
BORING

MANDRINI / ATTACCHI  
CHUCKS & CLAMPING SYSTEM

RICAMBI E LAVORAZIONI SUPP.  
SPARE PARTS & ADD. WORKING

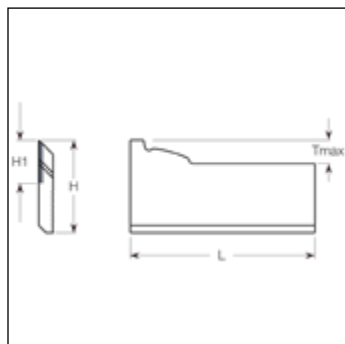
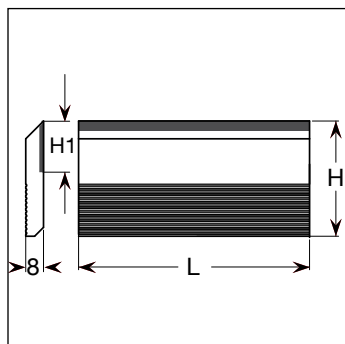

H	H1	Tmax
50	15	7
50	20	12
60	25	17

### NOT PROFILED KNIVES

● = Ready in stock ■ = Delivery time 20 working days △ = On request

L	H	H1	S	Code	€
60	50	15	8	● C207M0605015	
80	50	15	8	● C207M0805015	
100	50	15	8	● C207M1005015	
130	50	15	8	● C207M1305015	
150	50	15	8	● C207M1505015	
180	50	15	8	● C207M1805015	
230	50	15	8	● C207M2305015	
60	60	25	8	● C207M0606025	
80	60	25	8	● C207M0806025	
100	60	25	8	● C207M1006025	
130	60	25	8	● C207M1306025	
150	60	25	8	● C207M1506025	
180	60	25	8	● C207M1806025	
230	60	25	8	● C207M2306025	

Spec. C207M99

### PROFILED KNIVES

L	H	H1	S	Code	€
60	50	20	8	■ C208M0605020	
80	50	20	8	■ C208M0805020	
100	50	20	8	■ C208M1005020	
130	50	20	8	■ C208M1305020	
150	50	20	8	■ C208M1505020	
180	50	20	8	■ C208M1805020	
230	50	20	8	■ C208M2305020	

Spec. C208M99



## C207-C208 HW Profilable knives for T206-T206H-T206W cutterheads



Coltelli in HW zigrinati (spessore mm 8) • Disponibili in diverse misure • Fornibili grezzi o profilati • Indicati per la lavorazione di legni massicci • Da montare su teste portacoltelli T206-T206H-T206W

HW knurled knives (thickness 8 mm) • Available in different sizes • Supplied profiled or not profiled • Suitable for working solid wood • To mount on cutterheads T206-T206H-T206W

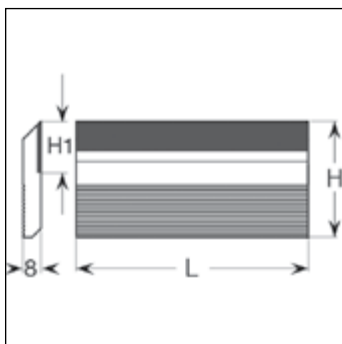

### NOT PROFILED KNIVES

● = Ready in stock ■ = Delivery time 20 working days △ = On request

L	H	H1	S	Code	€
60	70	30	8	● C207M0607030	
80	70	30	8	● C207M0807030	
100	70	30	8	● C207M1007030	
130	70	30	8	● C207M1307030	
150	70	30	8	● C207M1507030	
180	70	30	8	● C207M1807030	
230	70	30	8	● C207M2307030	
Spec.				C207M99	

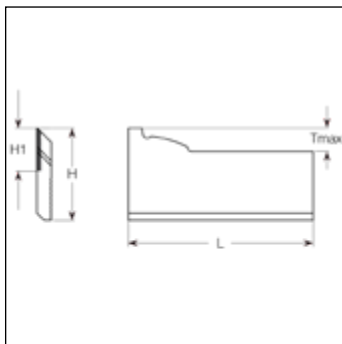

### PROFILED KNIVES

L	H	H1	S	Code	€
60	60	30	8	■ C208M0606030	
80	60	30	8	■ C208M0806030	
100	60	30	8	■ C208M1006030	
130	60	30	8	■ C208M1306030	
150	60	30	8	■ C208M1506030	
180	60	30	8	■ C208M1806030	
230	60	30	8	■ C208M2306030	
60	70	35	8	■ C208M0607035	
80	70	35	8	■ C208M0807035	
100	70	35	8	■ C208M1007035	
130	70	35	8	■ C208M1307035	
150	70	35	8	■ C208M1507035	
180	70	35	8	■ C208M1807035	
230	70	35	8	■ C208M2307035	
Spec.				C208M99	

H	H1	Tmax
60	30	22
70	30	22
70	35	27

TAGLIO / SEZIONATURA  
SAWING

DIAMANTE  
DIAMOND

FRESATURA  
CUTTING

PANTOGRAFATURA  
ROUTING

FORATURA  
BORING

MANDRINI / ATTACCHI  
CHUCKS & CLAMPING SYSTEM

RICAMBI E LAVORAZIONI SUPP.  
SPARE PARTS & ADD. WORKING





Coltelli HS profilabili per teste  
T206-T206H-T206W



HS Blanketts  
Rückenverzahnt  
für T206-T206H-T206W



Plaquettes HS de rechange  
por porte-outils  
T206-T206H-T206W



Ножи HS под  
профилрования для  
головок T206-T206H-T206W

## C205-C206

## HS Profilable knives for T206-T206H-T206W cutterheads



Coltelli in HS zigrinati (spessore mm 8) • Disponibili in diverse misure • Fornibili grezzi o profilati • Indicati per la lavorazione di legni massicci • Da montare su teste portacoltelli T206-T206H-T206W

HS knurled knives (thickness 8 mm) • Available in different sizes • Supplied profiled or not profiled • Suitable for working solid wood • To mount on cutterheads T206-T206H-T206W

TAGLIO / SEZIONATURA  
SAWING

DIAMANTE  
DIAMOND

FRESATURA  
CUTTING

PANTOGRAFATURA  
ROUTING

FORATURA  
BORING

MANDRINI / ATTACCHI  
CHUCKS & CLAMPING SYSTEM

RICAMBI E LAVORAZIONI SUPP.  
SPARE PARTS & ADD. WORKING

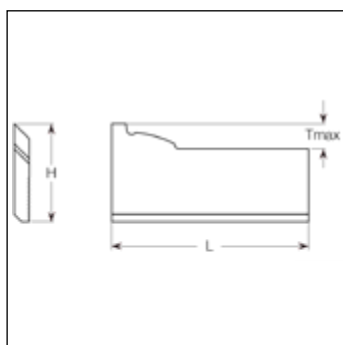
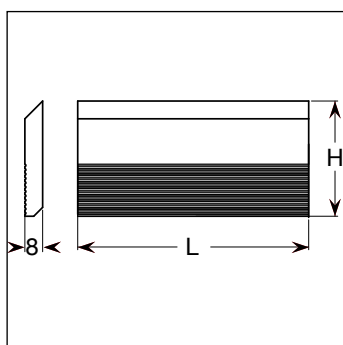

H	Tmax
50	12
60	20
70	30

NOT PROFILED KNIVES

● = Ready in stock ■ = Delivery time 20 working days △ = On request

L	H	S	Code	€
60	50	8	● C205S06050AA	
80	50	8	● C205S08050AA	
100	50	8	● C205S10050AA	
130	50	8	● C205S13050AA	
150	50	8	● C205S15050AA	
180	50	8	● C205S18050AA	
230	50	8	● C205S23050AA	
650	50	8	● C205S65050AA	
60	60	8	● C205S06060AA	
80	60	8	● C205S08060AA	
100	60	8	● C205S10060AA	
130	60	8	● C205S13060AA	
150	60	8	● C205S15060AA	
180	60	8	● C205S18060AA	
230	60	8	● C205S23060AA	
650	60	8	● C205S65060AA	
Spec.			C205S99	

PROFILED KNIVES

L	H	S	Code	€
60	70	8	■ C206S06070AA	
80	70	8	■ C206S08070AA	
100	70	8	■ C206S10070AA	
130	70	8	■ C206S13070AA	
150	70	8	■ C206S15070AA	
180	70	8	■ C206S18070AA	
230	70	8	■ C206S23070AA	
650	70	8	■ C206S65070AA	
Spec.			C206S99	



**AADO****Spacing collars**

Ottenuti da acciaio di ottima qualità • Disponibili in diverse misure • Superfici di appoggio totalmente rettificata • Da inserire nei gruppi frese e utensili vari

Obtained from steel with a high quality • Available in different sizes • Surfaces completely ground • To use with cutter sets and other tools

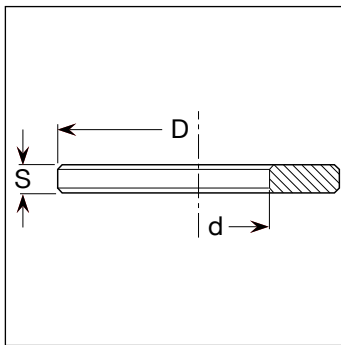

● = Ready in stock ■ = Delivery time 20 working days △ = On request

d	S	D	Code	€	d	S	D	Code	€
12	0,1	24	● AAD012024001		35	7	55	● AAD035055070	
12	0,2	24	● AAD012024002		35	8	55	● AAD035055080	
12	0,5	24	● AAD012024005		35	9	55	● AAD035055090	
12	1	24	● AAD012024010		35	10	55	● AAD035055100	
16	0,1	30	● AAD016030001		35	12	55	● AAD035055120	
16	0,2	30	● AAD016030002		35	15	55	● AAD035055150	
16	0,5	30	● AAD016030005		35	20	55	● AAD035055200	
16	1	30	● AAD016030010		40	0,1	60	● AAD040060001	
20	0,1	35	● AAD020035001		40	0,2	60	● AAD040060002	
20	0,2	35	● AAD020035002		40	0,5	60	● AAD040060005	
20	0,5	35	● AAD020035005		40	1	60	● AAD040060010	
20	1	35	● AAD020035010		40	2	60	● AAD040060020	
25	0,1	40	● AAD025040001		40	3	60	● AAD040060030	
25	0,2	40	● AAD025040002		40	4	60	● AAD040060040	
25	0,5	40	● AAD025040005		40	5	60	● AAD040060050	
25	1	40	● AAD025040010		40	6	60	● AAD040060060	
30	0,1	50	● AAD030050001		40	7	60	● AAD040060070	
30	0,2	50	● AAD030050002		40	8	60	● AAD040060080	
30	0,5	50	● AAD030050005		40	9	60	● AAD040060090	
30	1	50	● AAD030050010		40	10	60	● AAD040060100	
30	2	50	● AAD030050020		40	12	60	● AAD040060120	
30	3	50	● AAD030050030		40	15	60	● AAD040060150	
30	4	50	● AAD030050040		40	20	60	● AAD040060200	
30	5	50	● AAD030050050		50	0,1	70	● AAD050070001	
30	6	50	● AAD030050060		50	0,2	70	● AAD050070002	
30	7	50	● AAD030050070		50	0,5	70	● AAD050070005	
30	8	50	● AAD030050080		50	1	70	● AAD050070010	
30	9	50	● AAD030050090		50	2	70	● AAD050070020	
30	10	50	● AAD030050100		50	3	70	● AAD050070030	
30	12	50	● AAD030050120		50	4	70	● AAD050070040	
30	15	50	● AAD030050150		50	5	70	● AAD050070050	
30	20	50	● AAD030050200		50	6	70	● AAD050070060	
35	0,1	55	● AAD035055001		50	7	70	● AAD050070070	
35	0,2	55	● AAD035055002		50	8	70	● AAD050070080	
35	0,5	55	● AAD035055005		50	9	70	● AAD050070090	
35	1	55	● AAD035055010		50	10	70	● AAD050070100	
35	2	55	● AAD035055020		50	12	70	● AAD050070120	
35	3	55	● AAD035055030		50	15	70	● AAD050070150	
35	4	55	● AAD035055040		50	20	70	● AAD050070200	
35	5	55	● AAD035055050						
35	6	55	● AAD035055060						

Spec.

AAD99

Chiavi

Hakenschlüssel

Clés

Ключи

## ACH

## Wrenches

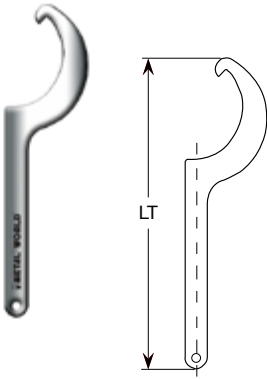

● = Ready in stock ■ = Delivery time 20 working days △ = On request

Ø	LT	Code	€
52-55	205	● ACH052AAAAAA	
58-62	240	● ACH058AAAAAA	
80	280	● ACH080AAAAAA	
100	280	● ACH095AAAAAA	
Spec.		ACH0099	

Chiavi esagonali  
con impugnatura a "T"

Sechskantschlüssel

Clés exagonales

Т-образные ключи

## ACHET

## "T" allen key

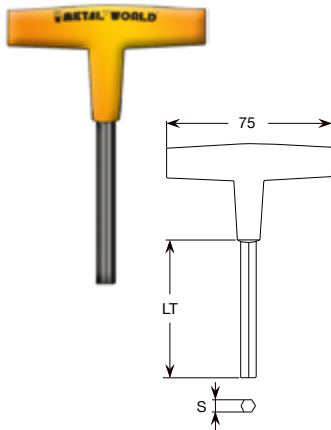

● = Ready in stock ■ = Delivery time 20 working days △ = On request

S	LT	Code	€
2,5	90	● ACHET25AAAAA	
3	90	● ACHET03AAAAA	
4	100	● ACHET04AAAAA	
5	110	● ACHET05AAAAA	
6	110	● ACHET06AAAAA	
6	200	● ACHET06HAAAAA	
8	200	● ACHET08HAAAAA	
10	200	● ACHET10HAAAAA	
Spec.		ACHET99	

Chiavi Torx  
con impugnatura  
a cacciavite

Torxschlüssel

Clés Torx

Ключи Торх

## ACHTC

## Torx key

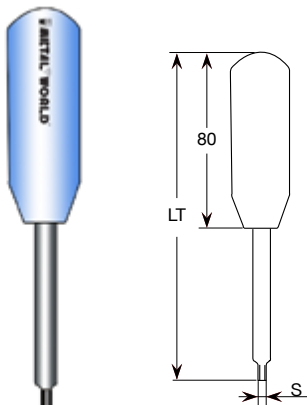

● = Ready in stock ■ = Delivery time 20 working days △ = On request

S	LT	Code	€
T5	130	● ACHTC05AAAAA	
T8	130	● ACHTC08AAAAA	
T9	130	● ACHTC09AAAAA	
T10	150	● ACHTC10AAAAA	
T15	160	● ACHTC15AAAAA	
T20	180	● ACHTC20AAAAA	
Spec.		ACHTC99	

TAGLIO / SEZIONATURA  
SAWINGDIAMANTE  
DIAMONDFRESATURA  
CUTTINGPANTOGRAFATURA  
ROUTINGFORATURA  
BORINGMANDRINI / ATTACCHI  
CHUCKS & CLAMPING SYSTEMRICAMBI E LAVORAZIONI SUPP.  
SPARE PARTS & ADD. WORKING

Chiavi Torx con impugnatura a "T"

Torxschlüssel

Clés Torx

T-образные ключи Torx



## ACHTT "T" Torx key

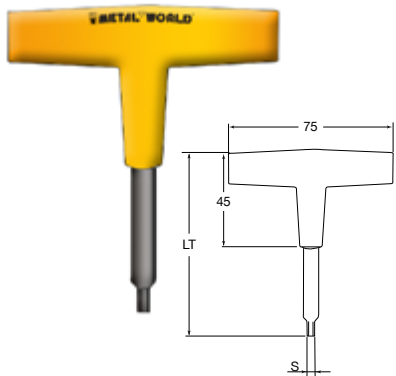

● = Ready in stock ■ = Delivery time 20 working days △ = On request

S	LT	Code	€
T9	90	● ACHTT09AAAAA	
T10	95	● ACHTT10AAAAA	
T15	95	● ACHTT15AAAAA	
T20	150	● ACHTT20AAAAA	
T25	150	● ACHTT25AAAAA	
Spec.		ACHTT99	

TAGLIO / SEZIONATURA  
SAWING

DIAMANTE  
DIAMOND

Supporti regolabili per smussatori e raggianti

Fräseinsätze für Fase-Abrundmesser

Support réglables pour couteaux à chanfreiner et arrondir

Подкладки для сменных резцов

## SUPP Adjustable supports for bevel/radius inserts

Ottenuti da acciaio bonificato • Indicati per il montaggio di inserti su teste portacoltelli di ogni genere • Il supporto viene fornito privo di coltelli

Obtained from hardened and tempered steel • Suitable for mounting inserts on any type of cutterheads • The support is supplied without knives

FRESATURA  
CUTTING

PANTOGRAFATURA  
ROUTING

FORATURA  
BORING

MANDRINI / ATTACCHI  
CHUCKS & CLAMPING SYSTEM

RICAMBI E LAVORAZIONI SUPP.  
SPARE PARTS & ADD. WORKING

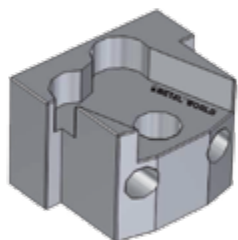

● = Ready in stock ■ = Delivery time 20 working days △ = On request

Code	€
● SUPP0AAAAA1	

Per montare coltelli C044M220R15A, C044M220R20A, C044M220R30A, C044M220AASA  
To mount C044M220R15A, C044M220R20A, C044M220R30A, C044M220AASA knives

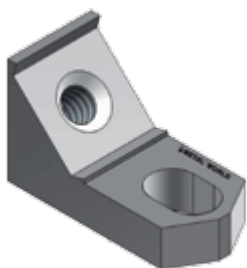

Code	€
● SUPP0AAAAA2	

Per montare coltelli C040M14020AA  
To mount C040M14020AA knives

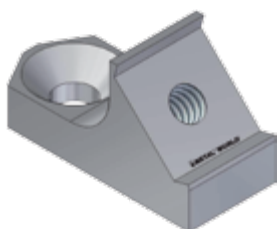

Code	€
● SUPP0AAAAA3	

Per montare coltelli C040M14020AA  
To mount C040M14020AA knives

## LAV

## Additional working

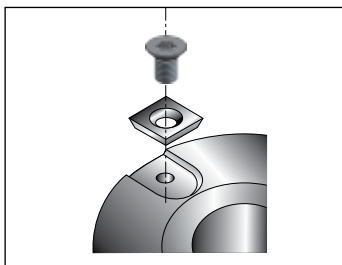
TAGLIO / SEZIONATURA  
SAWINGESECUZIONE SEDE CON RASANTE C040  
EXECUTION OF SPUR SEATS C040

Nr. of seats	€
2	
3	
4	
6	
8	

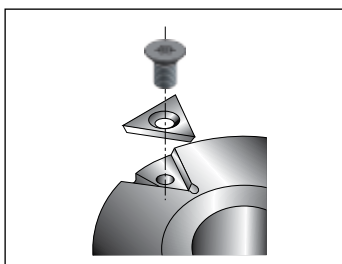
DIAMANTE  
DIAMONDFRESATURA  
CUTTINGESECUZIONE SEDE CON RASANTE TRIANGOLARE C042  
EXECUTION OF SEATS FOR TRIANGULAR SPURS C042

Nr. of seats	€
2	
3	
4	
6	
8	

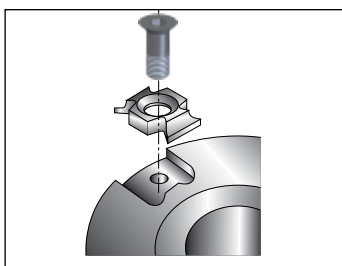
PANTOGRAFATURA  
ROUTINGFORATURA  
BORINGMANDRINI / ATTACCHI  
CHUCKS & CLAMPING SYSTEMESECUZIONE SEDE CON INSERTO SMUSSATORI RAGGIATORI C044  
EXECUTION OF SEATS FOR BEVEL/RADIUS INSERTS

Nr. of seats	€
2	
3	
4	
6	
8	

RICAMBI E LAVORAZIONI SUPP.  
SPARE PARTS & ADD. WORKING



**LAV** Additional working

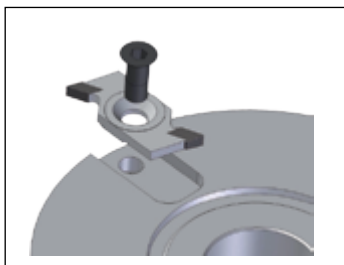

ESECUZIONE SEDE CON INSERTO PER INCASTRI C046 – C047 – C048  
EXECUTION OF GROOVING INSERT SEATS C046 - C047 - C048

Nr. of seats	€
2	
3	
4	
6	

TAGLIO / SEZIONATURA  
SAWING

DIAMANTE  
DIAMOND

FRESATURA  
CUTTING

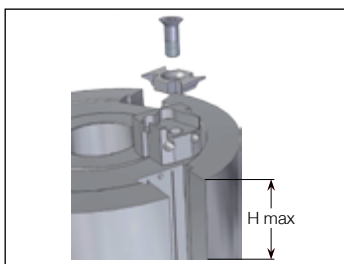

ESECUZIONE SEDE CON SUPPORTO REGOLABILE ED INSERTO SMUSSATORE-RAGGIATORE C044  
EXECUTION OF SEATS FOR ADJUSTABLE SUPPORTS FOR BEVEL/RADIOUS INSERTS C044

Nr. of seats	H max	€
2	50	
3	50	
4	50	
2	100	
3	100	
4	100	
2	150	
3	150	
4	150	

PANTOGRAFATURA  
ROUTING

FORATURA  
BORING

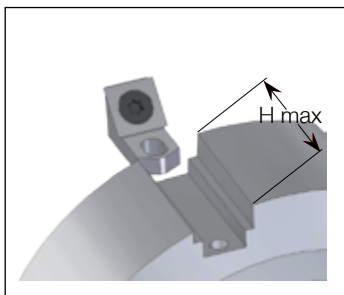

ESECUZIONE SEDE CON SUPPORTO REGOLABILE E RASANTE C040  
EXECUTION OF SEATS FOR ADJUSTABLE SUPPORTS AND SPURS C040

Nr. of seats	H max	€
2	50	
3	50	
4	50	
6	50	
2	100	
3	100	
4	100	
6	100	

MANDRINI / ATTACCHI  
CHUCKS & CLAMPING SYSTEM

RICAMBI E LAVORAZIONI SUPP.  
SPARE PARTS & ADD. WORKING



PROFESSIONAL TOOLS ALL OVER THE WORLD